

# **Chemical Solution Feed Pumps - Operation and Maintenance**

**TSAG**

**February 2010**

# Chemical Solution Feed Pumps

**Why do we treat water?**

**Chemical Feed - Background**

# Chemical Feed Pumps Many sizes and styles available



# Solution Chemical Feeders

- **Positive Displacement Chemical Pumps**
- **Reciprocating Diaphragm Pumps**
  - **Mechanical**
  - **Hydraulic**
  - **Piston**
  - **Solenoid**
- **In line Screw Action**
- **Rotary Impeller Action**
- **Peristaltic**

# Reciprocating Diaphragm Pumps

- **Motor Driven**
- **Solenoid Driven**

# Positive Displacement Diaphragm Pumps

- **Drive rod connected directly to the diaphragm**
- **Adjustment by speed or stroke length**
- **Increase pump chamber volume to receive the chemical and decrease the pump chamber volume to push the chemical to point of use**
- **A series of inlet and outlet check valves control the fluid movement.**

# Diaphragm Pumps

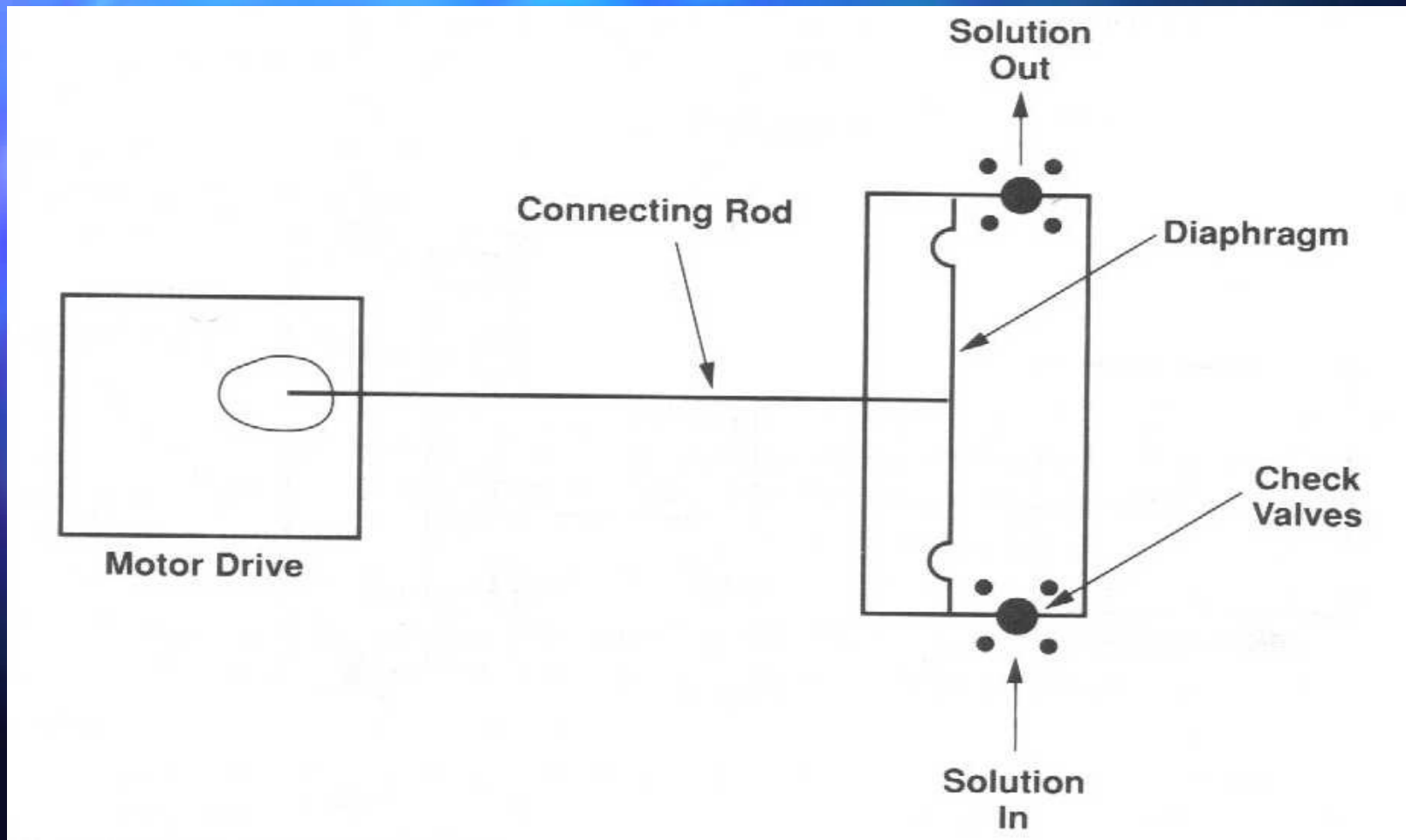

# Diaphragm Pumps

## Reciprocating Diaphragm Metering Pump Stroke Cycle

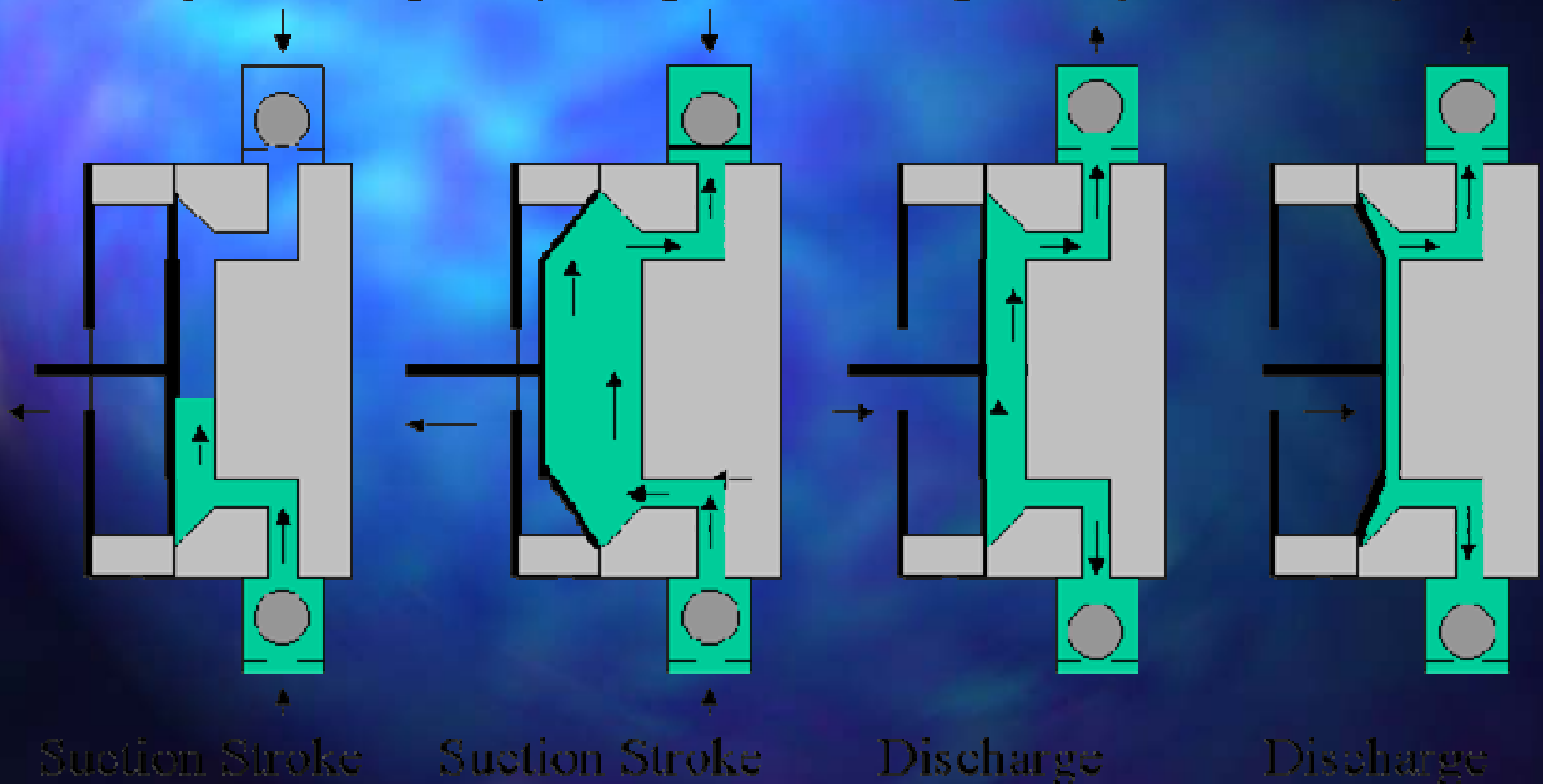

# Diaphragm Pumps

- **Pump Adjustment**
  - **Volume per stroke**
  - **Strokes per minute**

# Feed System Components

---

# Selecting A Feed System

- **Size (capacity)**
- **Pressure**
- **Chemical**
  - **Compatibility, Viscosity, Characteristics**
- **Location**
  - **suction and discharge lines**
  - **Temp**
  - **Power**

# Materials of Construction

- **Use the manufacturers chemical compatibility charts when making pump selection.**
- **Wetted parts should be Compatible with chemical being transported.**
- **Pump body should be resistant to corrosion from the chemical.**

# Parts of a feed System

- **Solution Barrel or Tank**
- **Mixer**
- **Foot Valve, Suction assembly**
- **Pumping Head**
- **Anti-Siphon**
- **Calibration Vessel**
- **Back Pressure, Pressure Relief**
- **Pulsation Dampener**
- **Injector and Discharge Assembly**

# Feeder Operation

- **Think safety!**
  - Chem feed systems operate under pressure
  - Use protective equipment

# Solution Preparation

- **Use calibrated measuring equipment**
- **all containers must be compatible**
- **Know your solution strength**
  - **calculations !**

# Calibration

- **Calibrate any time system changes**
  - **New equipment**
  - **maintenance of feeder**
  - **change in system pressure**
  - **change in chemical concentration/viscosity**

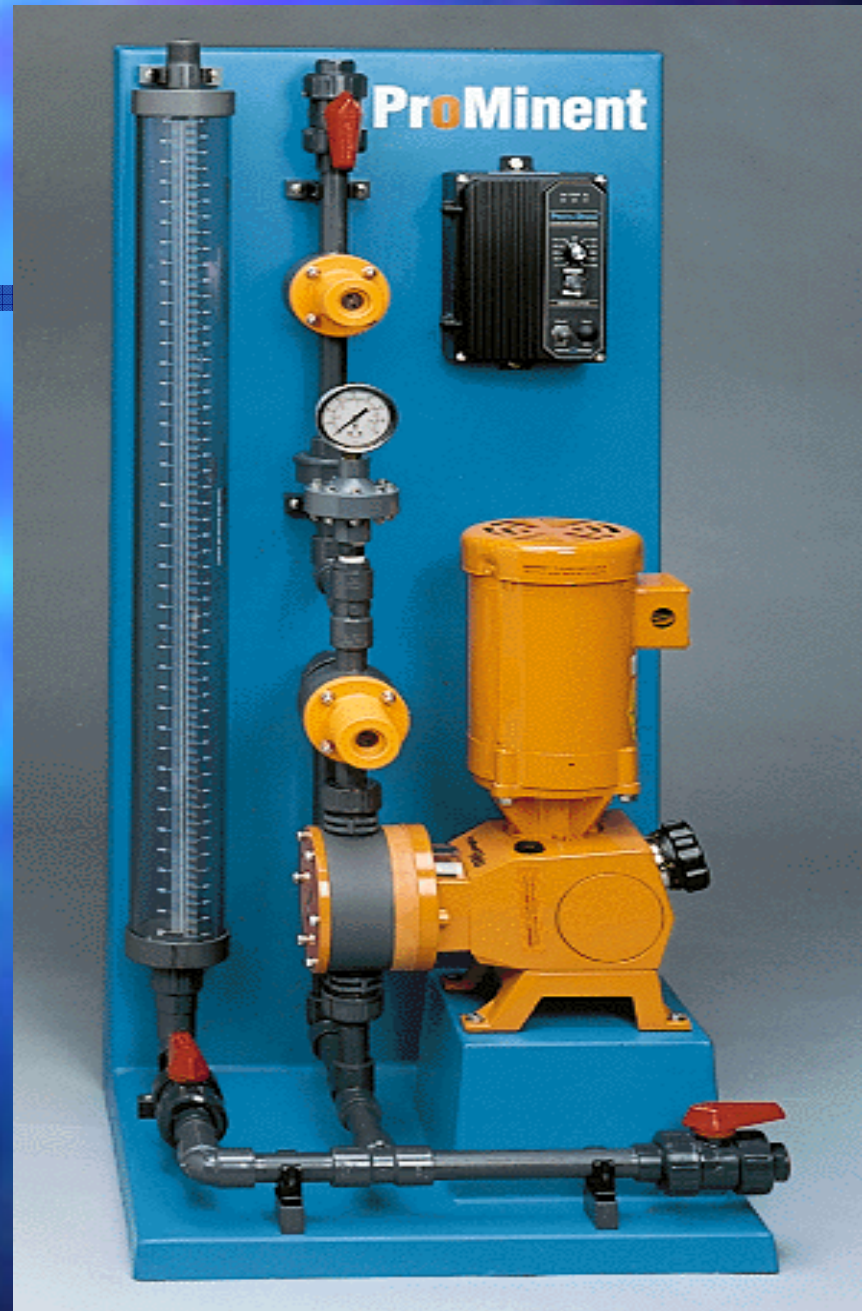

# Calibration

- **Measure Volume pumped over time**
  - **mls/min, liter/hr, gal/day etc.**
- **Calibrate from suction side of pump**
- **calibrate to one variable only**
- **information from calibration is recorded and then plotted on a graph to give us a calibration curve.**

# Typical Calibration Curve

## Pump Calibration Curve

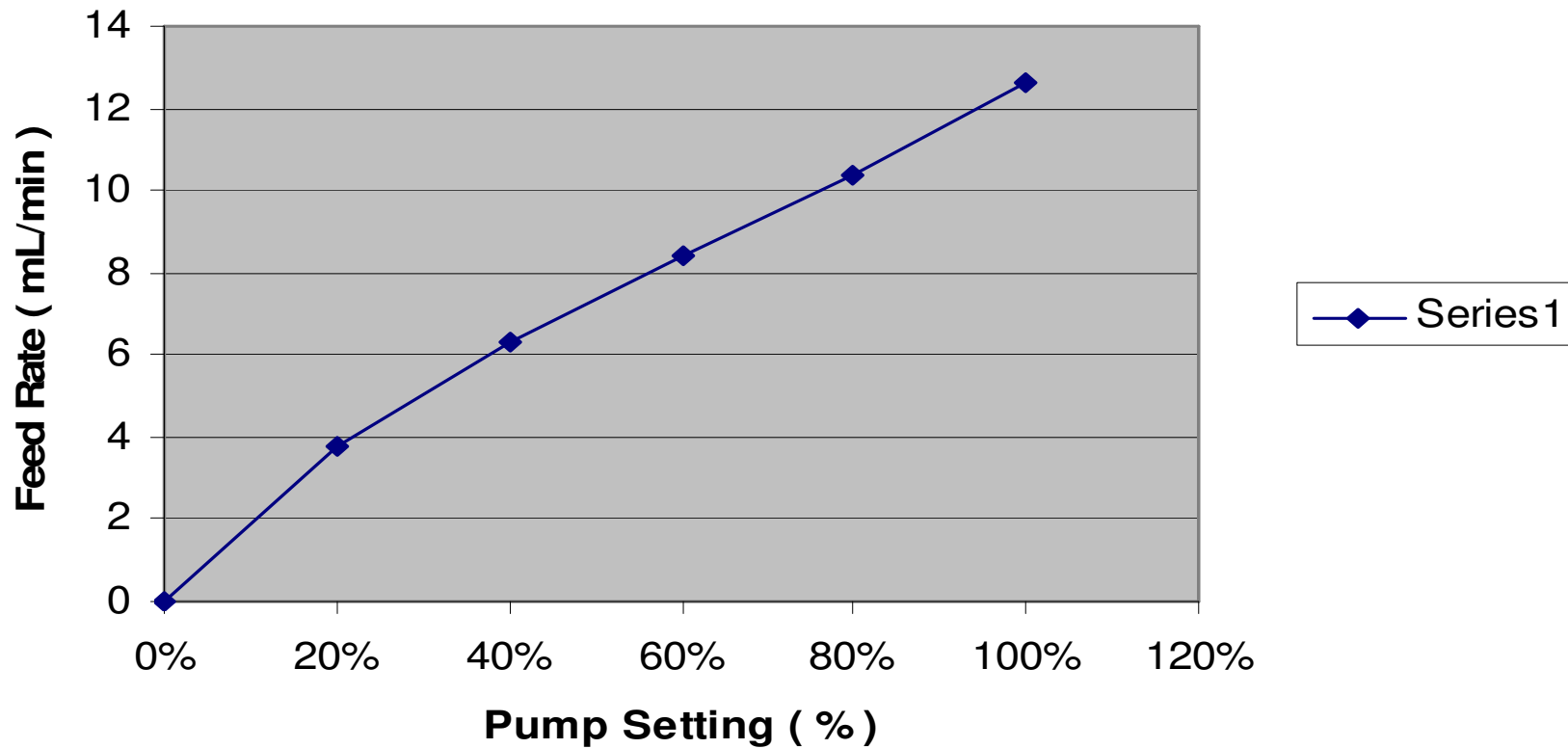

# Preparing for calibration

- **Proper equipment**
  - Calibration column or graduated cylinder
  - Stop watch
  - Pen, notebook, graph paper
  - Calculator
- **Determine variable and settings**
- **Determine time per measurement**
- **Ensure pump is primed**
- **Ensure sufficient chemical is available**

# Example Calibration

Pump Setting	Pump Output	Feed Rate	Plant Flow	Chem Conc.	Dosage
	ml / 5 min	ml / min	l / min	mg / ml	mg / L
100%			150	120	
80%			150	120	
60%			150	120	
40%			150	120	
20%			150	120	
0%			150	120	

# Example Calibration

Pump Setting	Pump Output	Feed Rate	Plant Flow	Chem Conc.	Dosage
	ml / 5 min	ml / min	l / min	mg / ml	mg / L
100%	62.8		150	120	
80%	51.9		150	120	
60%	42.2		150	120	
40%	31.3		150	120	
20%	18.8		150	120	
0%	0		150	120	

# Example Calibration

Pump Setting	Pump Output	Feed Rate	Plant Flow	Chem Conc.	Dosage
	ml / 5 min	ml / min	l / min	mg / ml	mg / L
100%	62.8	12.6	150	120	
80%	51.9	10.4	150	120	
60%	42.2	8.4	150	120	
40%	31.3	6.3	150	120	
20%	18.8	3.8	150	120	
0%	0	0	150	120	

# Example Calibration

Pump Setting	Pump Output	Feed Rate	Plant Flow	Chem Conc.	Dosage
	ml / 5 min	ml / min	l / min	mg / ml	mg / L
100%	62.8	12.6	150	120	10.1
80%	51.9	10.4	150	120	8.3
60%	42.2	8.4	150	120	6.8
40%	31.3	6.3	150	120	5
20%	18.8	3.8	150	120	3
0%	0	0	150	120	0

# Example Calibration - Graph

- **basic graph paper**
- **line graph**
- **2 axis**
  - **Horizontal**
    - **variable setting - 0- 100 %**
  - **Vertical**
    - **your choice**
- **Plot Data**
- **Draw Curve**

# Example Calibration - Graph

**Pump Calibration Curve**

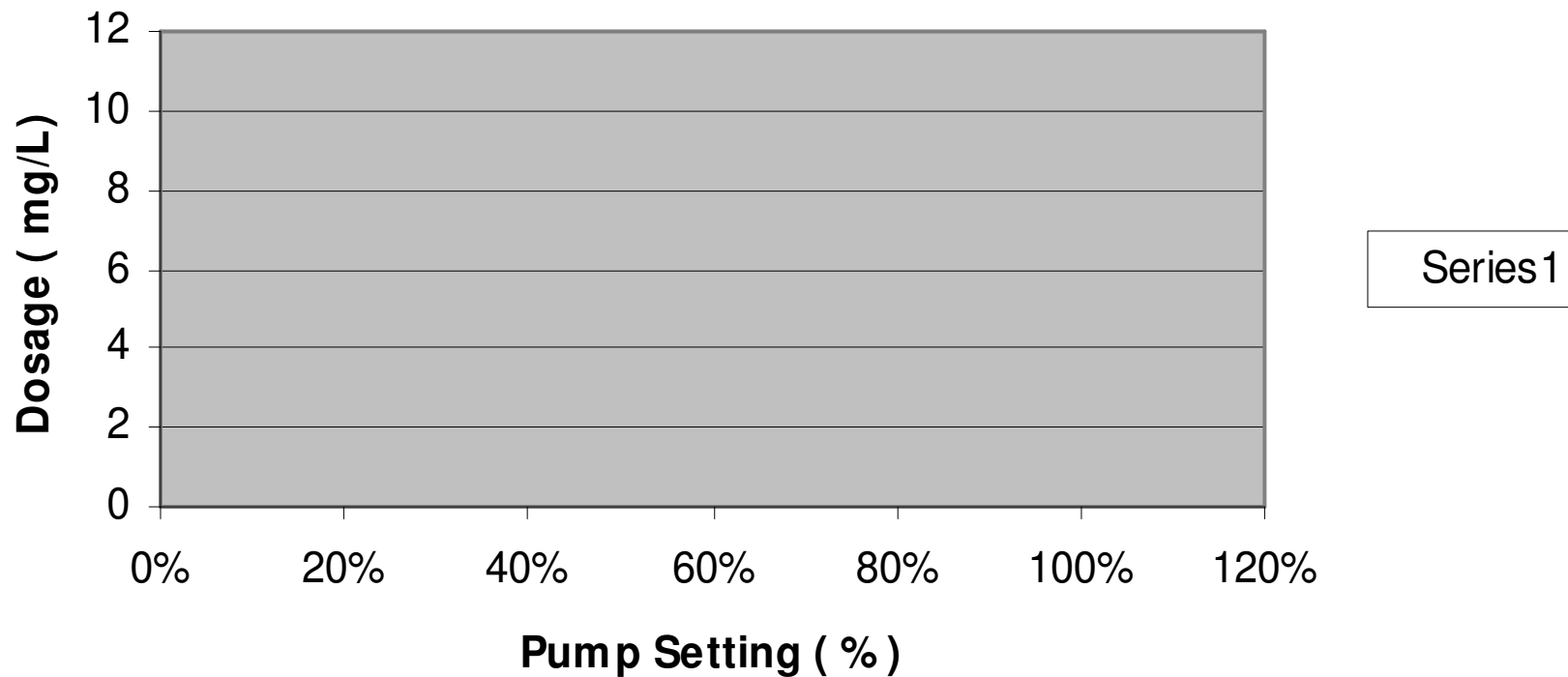

# Example Calibration - Graph

**Pump Calibration Curve**

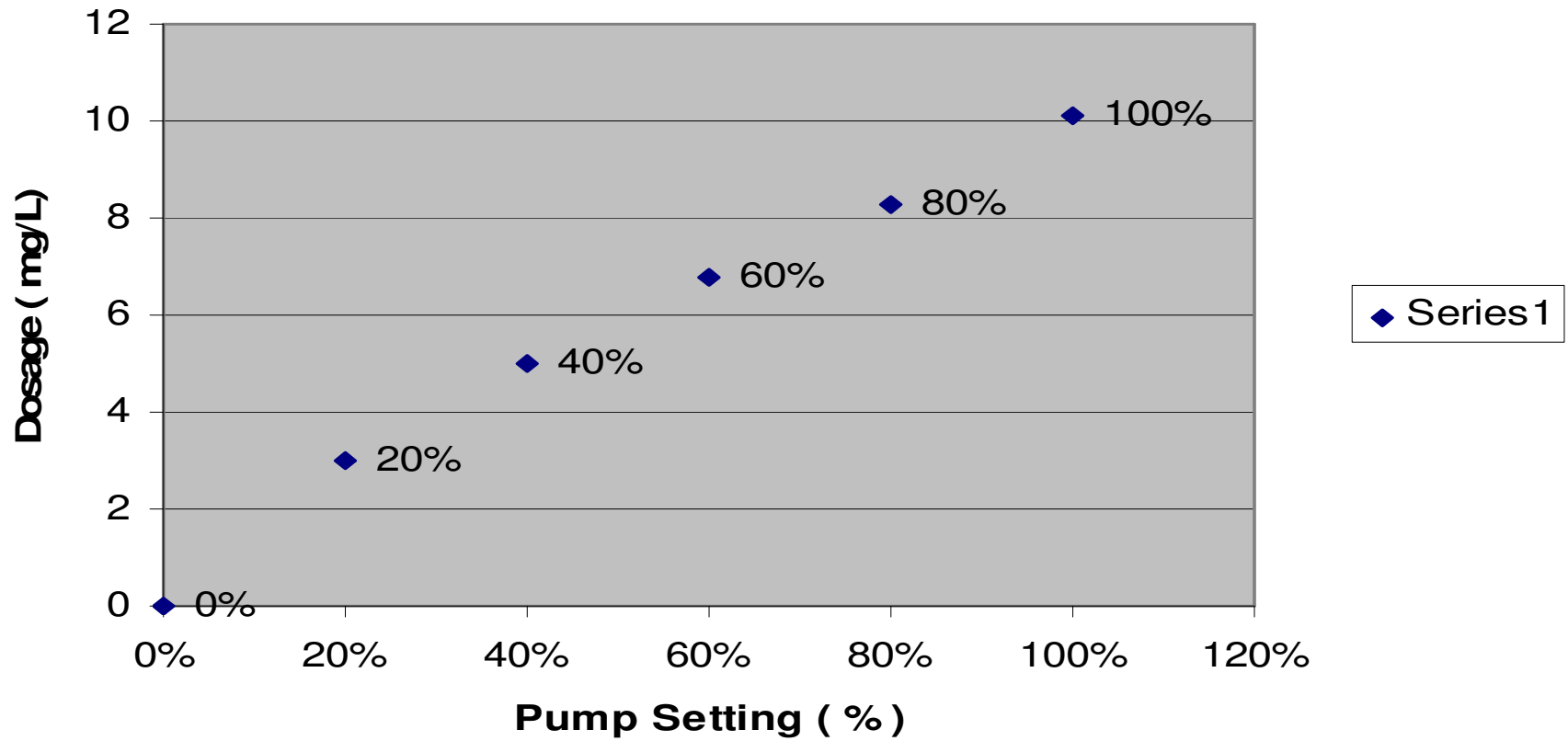

# Example Calibration - Graph

## Pump Calibration Curve

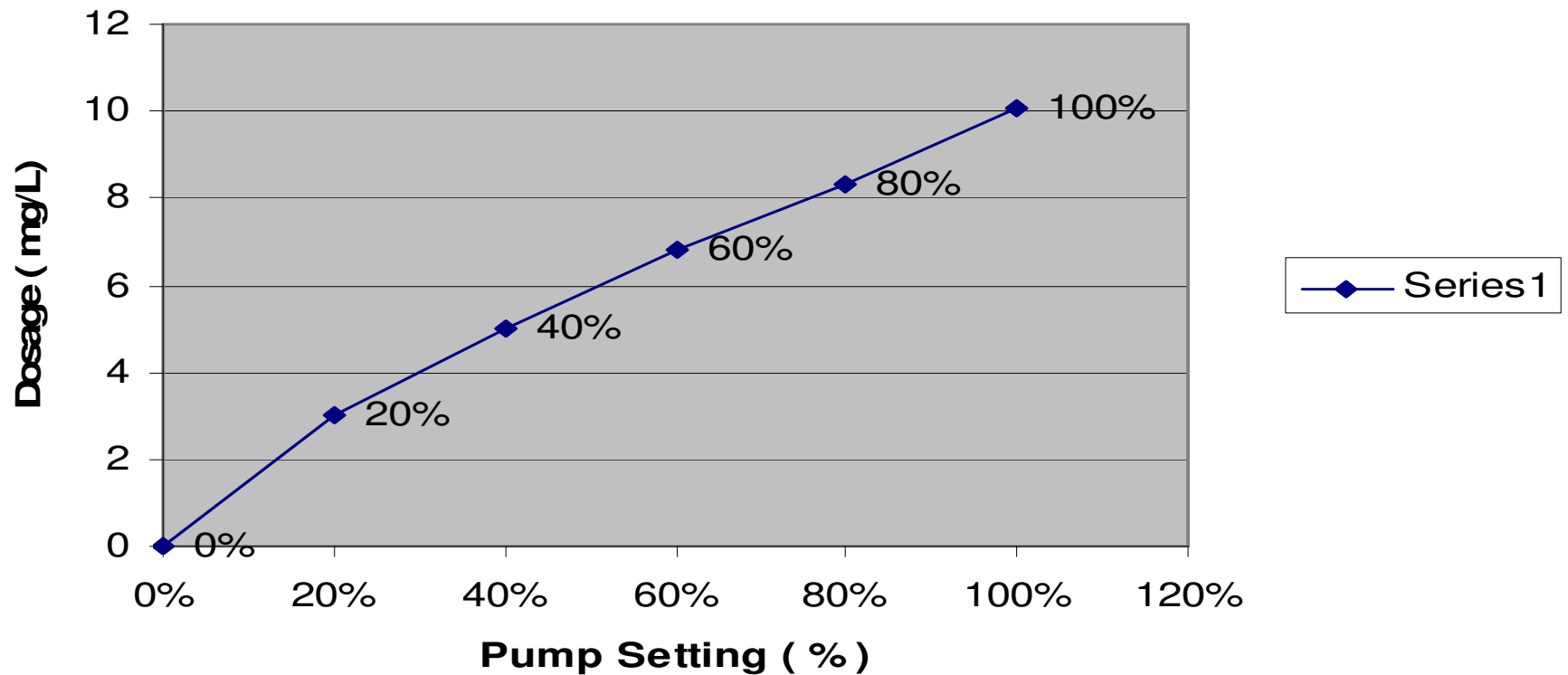

# Chemical Feed Pump Maintenance

---

# Chemical Feed Pump Maintenance

## Draining the System

- **Disconnect Power**
- **Remove suction side from feed barrel**
- **Disconnect injection point**
- **Disconnect suction and discharge valves from pumping head**
- **Drain liquid end**
- **ALWAYS USE SAFETY EQUIPMENT**

# Chemical Feed Pump Maintenance

- **Biggest Concern: Buildup of deposits**
- **Prevents valve seats from sealing properly and lead to drop off in feed or complete failure**
- **Cause diaphragm to distort or rupture**
- **Plug lines and injection points causing pressure buildup, output change, and possible diaphragm failure**

# Chemical Feed Pump Maintenance

- Clean with Hot Sudsy Water if deposits are water soluble.
- Use chemical cleaners if required.
- Check and clean injection point regularly.
- Replace seals/gaskets at check valves.
- Replace diaphragm if there are any visible distortions or nonconformity's
- Spare Parts and Standby Pumps Onsite

# Chemical Feed Pump

---

## Troubleshooting

# Feed pumps are affected by:

- **Pressure**
- **Viscosity**
- **Suction Conditions**
- **Discharge Conditions**
- **Solids and Residue**
- **Chemical attack**

## Problem: Pump has reduced output or will not operate to rated pressure

- Check process line pressure and compare to pump rating.
- Check discharge lines and injection valve for blockage
- Diaphragm out of adjustment, worn, or damaged.
- Checkvalve balls and/or seats worn, corroded or scaled
- tank or drum not vented properly
- air lock in liquid end.

# Problem: Pump will not prime

- Check Suction lift
- check chemical viscosity and specific gravity Vs pump rating
- increase stroke and speed to maximum during prime
- relieve discharge tubing to atmosphere
- keep foot valve and tubing vertical
- eliminate air traps, kinks, and bends in tubing
- pre-prime liquid end

# Problem: Loss of Prime

- Check chemical level
- Check position of foot valve
- Check suction side of pump, potentially introduction of air before the liquid end
- check seals, do not over tighten
- replace suction tubing
- if pumping a chemical that evolves gas install a degassing liquid end, flooded suction, or multifunction valve.

# Problem Excessive Pump

## Output: Siphoning

- **Avoid injection points significantly below the chemical pump/tank**
- **Repair or replace injection valve**
- **install a back pressure valve in the discharge line**

**Any Questions??**

---